

# Data Sheet 7

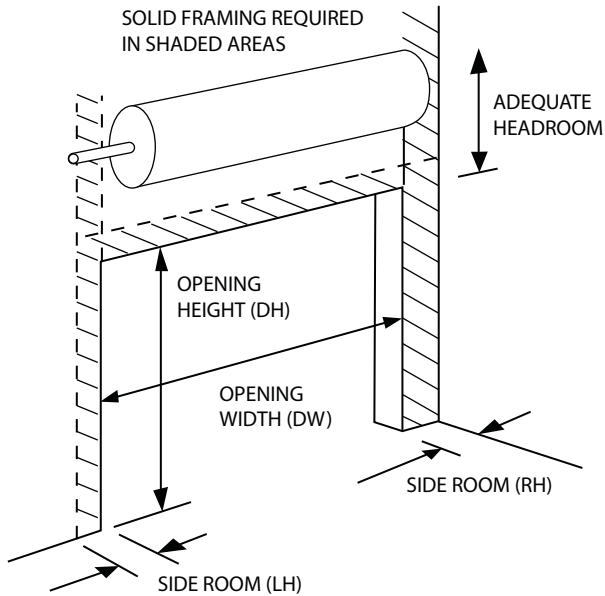

## IMPORTANT CONSIDERATIONS FOR PLANNING AND INSTALLATION

FOLDING CLOSURES } ROLLER GRILLIES } ROLLER SHUTTERS



REMEMBER THE DOOR IS A PIECE OF HEAVY MACHINERY & WILL REQUIRE SOMETHING SOLID TO ATTACH TO.

OPENING TO BE FORMED IN ACCORDANCE WITH NZ BUILDING CODE 3604 & ADEQUATE TO SUPPORT DOOR. (NOT METAL STUD).

**HEADROOM** - ADEQUATE TO ACCOMMODATE ROLL SIZE, AS WELL AS ANY OTHER SERVICES, INCLUDING CEILING THICKNESS, BRACING, PIPING, DUCTING AND DOWN LIGHTS ETC.

**ACCESS PANELS** - RECOMMENDED FULL WIDTH OF OPENING FOR FUTURE SERVICING OF ROLLER DOOR, SHOULD IT BE CONCEALED INSIDE BULKHEAD OR CEILING

**SIDEROOM** - ADEQUATE TO ACCOMMODATE DOOR TRACKS BELOW CEILING & ADDITIONAL SIDE ROOM ABOVE OPENING TO ACCOMMODATE DOOR SHAFT, DOOR BRACKETS, MOTORISING AND SERVICING

**LOCKING** - DOUBLE SIDED DEADLOCK, SNIB TURN INTERNALLY FOR FIRE EGRESS, OFF CENTRE FOR EASY ACCESS

